



The Mid Valley Messenger

Mid Valley Air Park Property Owners Association, Inc • PO Box 64 Los Lunas, NM 87031 • Vol 1 No 3 • February 1999

OFFICERS

President/Planning/News

Charlie Hott
23 Elaine Drive
865-1859

Vice President/Runway

Dick Horton
317 Hathaway Drive
866-0454

Secretary/Architectural

Frank Johnson
518 Debonair
866-9328

Treasurer/Grounds

Gerry Donovan
6 Bonnie Street
865-7434

Member at Large/Roads

Becky Lutz
Mooney Court
865-6587

Alternate/Parliamentarian

Bob Nesbitt
4500 Elaine Drive
884-4720

1998-99 MEETINGS

*Quarterly Board**

April 12
July 12

*Monthly Board***

February 11
March 11
May 13
June 10
August 12

Annual

September TBA

*LL Council Chambers
660 Main St, Los Lunas

**open to members, but
limited space- contact
President in advance

President's Message

I was anxious about my first MVAPOA Board of Directors meeting as President. I wanted to have an orderly, productive meeting. If you were not there, you missed a good meeting. Thanks to all the committee chairs and my fellow board members for their time and energy. I JUST WISH WE COULD GET MORE OF YOU INVOLVED. Elsewhere in this newsletter, I have listed our association's committees and their membership. Please note, as I did, that the same handful of volunteers seem to be doing all the work. I urge you to volunteer to serve on one of these committees. Your input is vital to the continued existence of this neighborhood. Even if you are not interested, maybe you know someone who is. Call them and encourage them to serve!

Our "thorn in the flesh" thus far this year seems to be runway setbacks. It would have been nice if FAA requirements were adhered to from the beginning, but they were not. We are left with outdated covenants that are not as safe as they could be, and precedents.

We as your Board will strive to represent the your best interests and to make this a pleasant, safe community. We intend to accomplish this by looking at precedents, compromising when applicable, and by revising the covenants. 1998 was the year of the new bylaws. I hope 1999 can be the year of the new covenants.

Runway Setback Moratorium

In December it was discovered that a new structure was finally going to be built in the commercial section by the EAA and Warren Janke. The plans for this structure were approved a year ago by a previous board and architectural committee.

FAA guidelines regarding runway setbacks call for 75' from centerline plus a slope of 7 to 1 (see figure below). As noted in the President's Message, this airpark was not designed with these setbacks in mind. In the interest of safety, your Board is in favor of coming as close to this recommended setback as is reasonable, given airpark layout and precedents.

The closest existing structure to the North-South runway centerline, (not counting the South over run area) is the Los Lunas Bicycle Shop/Hangar. A creative solution to the EAA/Janke hangar placement was proposed by Kurt Winker and accepted by the EAA and Warren. It calls for the combining of two lots and a setback no less than the bicycle shop.

In light of this compromise, your Board and its Architectural Advisory Commit-

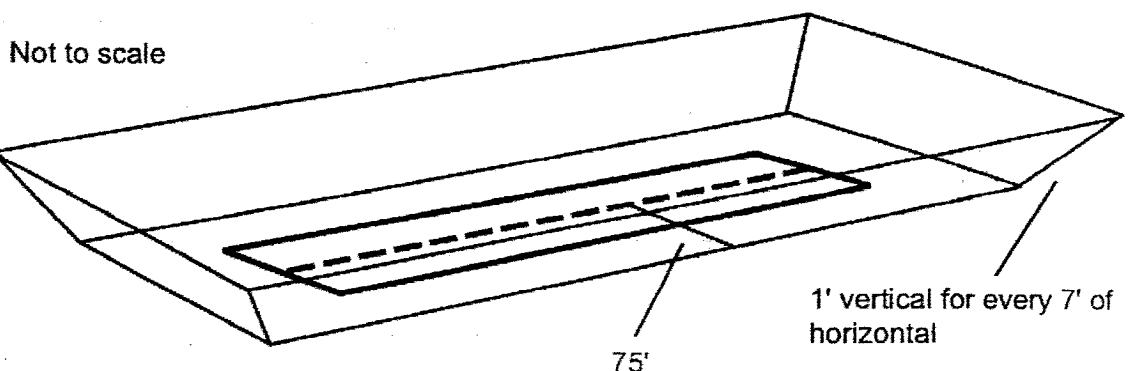

tee would like to ask that a moratorium be observed on construction of any structures over 9' tall within 137' from the north/south runway centerline, south of east/west drive. This moratorium is in place until the covenants can be revised by the Architectural Advisory Committee and approved by the membership.

New Neighbors!

The Architectural Advisory Committee and your Board of Directors have approved the house plans for Larry & Karen Helwig. The Helwig's new house will be adjacent to the East-West runway, west of the Johnsons and South of the Lardners.

Larry was born and raised in south St. Paul, Minnesota. and Karen in Sandstone, Minnesota. They were married on April 15, 1967. Larry & Karen have three children: Laura was born in Texas and the twins Kelly & Kurt were born in North Carolina. Laura is married and living in Oklahoma City, Kelly is married and living in Los Lunas and Kurt will be engaged as of 01/08/99 to a girl from Wichita Falls, Texas. They have ONE GRANDSON, Nathan, who lives in Los Lunas, so they get to see him often!

Larry served in the United States Air Force for 27 years, so their family has lived in Washington state, Texas, North Carolina, New Mexico, Okinawa & Turkey.

Larry's hobby is flying! It doesn't matter if it is for work or pleasure - he is happy in an airplane! Making their home in Mid Valley Air Park is like a dream come true for them. The Helwigs attend the Hoffmantown Church in Albuquerque. Welcome to the neighborhood Larry & Karen!

Committees! Your chance to get involved!

ARCHITECTUAL

Current Projects: building plan approval procedures, covenant revision

Rich Chavez, Co-Chair, 565-1079

Ann Stansel, Co-Chair, 865-5866

Frank Johnson, Board Liaison

Karla Johnson

Becky Lutz

ROADS

Current Projects: phased plan for road repair, new signs

Dave Turba, Chair, 865-4216

Becky Lutz, Board Liaison

Kurt Winker

RUNWAY

Current Projects: written aircraft operations procedures, maintenance, easements, controlling runway incursions, taxiway lights

Kurt Winker, Chair, 565-1041

Dick Horton, Board Liaison

Dave McIntosh

Jack Hickman

Marv Kaylor

PLANNING

Current Projects: monitoring I25 bypass, new house numbering, clubhouse, security, directory

Marv Kaylor, Chair, 866-9338

Charlie Hott, Board Liaison

Kurt Winker

Pete Rael

GROUNDS

Current Projects: gopher control, gating of Conservancy roads, mowing

Vince Lardner, Chair, 865-3553

Gerry Donovan, Board Liaison

Dave Hamann